

## BYPASSING THE BMW EWS II ANTI-THEFT SYSTEM

- ▶ All BMW vehicles, 1995 and newer, use an Electronic Immobilization System called EWS II. The EWS II system uses an antenna ring around the ignition cylinder to energize a small transponder chip hidden in the key. When the ignition is turned on, this chip is energized and the antenna ring sends the code to the one of the vehicle's computers. If the code is correct the vehicle is allowed to start and run. If an invalid code is sent, the vehicle will not start. When installing a remote start system, it is necessary to bypass the system while the vehicle is remote started. This interface will allow the system to function normally, still protecting the vehicle, while bypassing the system when remote starting.
- ▶ This interface will require purchasing one EWS steering wheel lock antenna ring. Part # 66-008362278 from your local BMW dealer. This part generally costs between \$20-\$30. A spare key is also required. This can be either the ABS emergency key or the standard metal key.



### NOTE:

It is recommended that the shaft of the key be cut prior to use so that if found by a thief it will not turn in the ignition cylinder.

### TO INTERFACE WITH THE EWS II SYSTEM:

- 1 At the ignition harness you will find GREEN and PURPLE or (PURPLE/WHITE) wires that need to be energized as ignition wires.
- 2 Find the two small gauge LT.GREEN wires going between the ignition switch cylinder and the EWS II transceiver module.
- 3 Wire the relay as shown with the new antenna ring and the key making sure the head of the key is in the middle of the ring.
- 4 The new antenna ring and the attached key should be well hidden behind the dash area. Try to keep a distance of at least 18 inches between the original ignition ring and the new one to keep the two from interfering with each other.

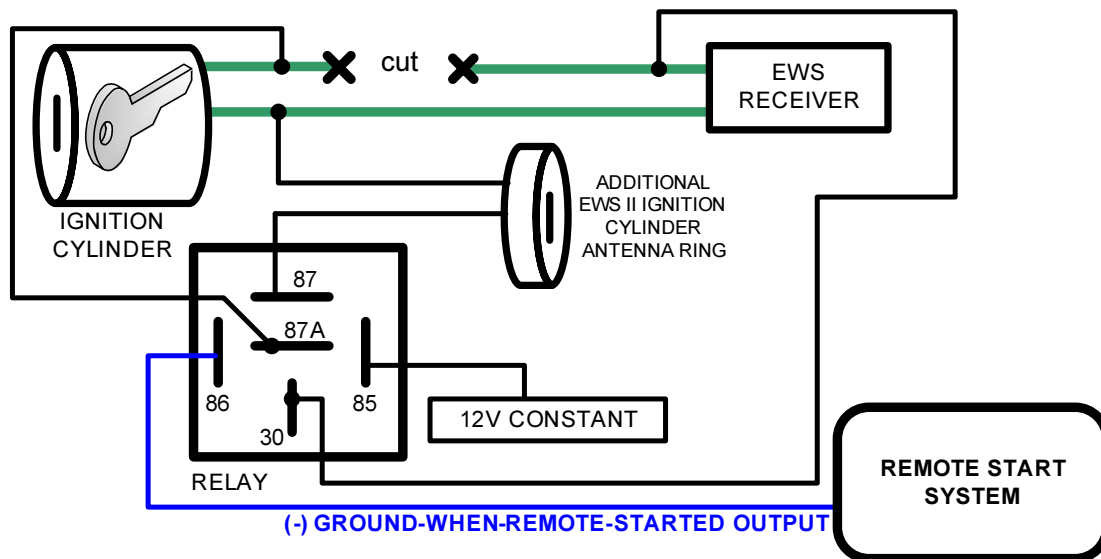

PIN	CONNECTION
85	TO 12V CONSTANT
86	TO (-) GROUND-WHEN-REMOTE-STARTED-OUTPUT FROM REMOTE START SYSTEM
87	TO EWSII CYLINDER KEYRING
87A	TO CUT LT.GREEN WIRE – IGNITION CYLINDER SIDE
30	TO CUT LT.GREEN WIRE – EWS RECEIVER CYLINDER SIDE

Remote starter and security installations should be attempted by experienced security installers only. Information contained is accurate to the best of our knowledge and experience. Information contained is without any representation of warranty. It is the installer's responsibility to test and confirm all circuits with a digital multi-meter. Proper installation remains the responsibility of the installer. CarInstallExperts.com assumes no liability or responsibility resulting from an improper installation, even in reliance with the information contained in this guide.